

# Keysight Add 4-Port Capability Upgrade Kit

To Upgrade PNA N5221A or N5222A Option 219 to Option 419

Upgrade Kit Order Numbers: N5221AU- 619 and N5222AU- 619

Keysight Kit Number: N5222-60114

NOTICE: This document contains references to Agilent Technologies. Agilent's former Test and Measurement business has become Keysight Technologies. For more information, go to [www.keysight.com](http://www.keysight.com).



---

## WARRANTY STATEMENT

THE MATERIAL CONTAINED IN THIS DOCUMENT IS PROVIDED "AS IS," AND IS SUBJECT TO BEING CHANGED, WITHOUT NOTICE, IN FUTURE EDITIONS. FURTHER, TO THE MAXIMUM EXTENT PERMITTED BY APPLICABLE LAW, KEYSIGHT DISCLAIMS ALL WARRANTIES, EITHER EXPRESS OR IMPLIED WITH REGARD TO THIS MANUAL AND ANY INFORMATION CONTAINED HEREIN, INCLUDING BUT NOT LIMITED TO THE IMPLIED WARRANTIES OF MERCHANTABILITY AND FITNESS FOR A PARTICULAR PURPOSE. KEYSIGHT SHALL NOT BE LIABLE FOR ERRORS OR FOR INCIDENTAL OR CONSEQUENTIAL DAMAGES IN CONNECTION WITH THE FURNISHING, USE, OR PERFORMANCE OF THIS DOCUMENT OR ANY INFORMATION CONTAINED HEREIN. SHOULD KEYSIGHT AND THE USER HAVE A SEPARATE WRITTEN AGREEMENT WITH WARRANTY TERMS COVERING THE MATERIAL IN THIS DOCUMENT THAT CONFLICT WITH THESE TERMS, THE WARRANTY TERMS IN THE SEPARATE AGREEMENT WILL CONTROL.

---

## DFARS/Restricted Rights Notice

If software is for use in the performance of a U.S. Government prime contract or subcontract, Software is delivered and licensed as "Commercial computer software" as defined in DFAR 252.227-7014 (June 1995), or as a "commercial item" as defined in FAR 2.101(a) or as "Restricted computer software" as defined in FAR 52.227-19 (June 1987) or any equivalent agency regulation or contract clause. Use, duplication or disclosure of Software is subject to Keysight Technologies' standard commercial license terms, and non-DOD Departments and Agencies of the U.S. Government will receive no greater than Restricted Rights as defined in FAR 52.227-19(c)(1-2) (June 1987). U.S. Government users will receive no greater than Limited Rights as defined in FAR 52.227-14 (June 1987) or DFAR 252.227-7015 (b)(2) (November 1995), as applicable in any technical data.

---

## Safety Notes

The following safety notes are used throughout this document. Familiarize yourself with each of these notes and its meaning before performing any of the procedures in this document.

---

**WARNING**      **Warning denotes a hazard. It calls attention to a procedure which, if not correctly performed or adhered to, could result in injury or loss of life. Do not proceed beyond a warning note until the indicated conditions are fully understood and met.**

---

---

**CAUTION**      Caution denotes a hazard. It calls attention to a procedure that, if not correctly performed or adhered to, could result in damage to or destruction of the instrument. Do not proceed beyond a caution sign until the indicated conditions are fully understood and met.

---

---

## Description of the Upgrade

This upgrade converts your N5221A or N5222A Option 219 2-port analyzer to a N5221A or N5222A Option 419 4-port analyzer by adding:

- an additional source
- an additional source synthesizer
- an additional mixer brick
- two additional receiver couplers
- two additional test port couplers
- two additional bias tees
- two additional source attenuators
- two additional receiver attenuators
- a splitter
- a modified front panel
- an additional cable guard
- new cables

---

## Getting Assistance from Keysight

Installing this upgrade kit requires special skills and experience. If you think you may not be qualified to do the work, or need advice, contact Keysight.

### Contacting Keysight

Assistance with test and measurements needs and information on finding a local Keysight office are available on the Web at:

<http://www.keysight.com/find/assist>

If you do not have access to the Internet, please contact your Keysight field engineer.

---

**NOTE** In any correspondence or telephone conversation, refer to the Keysight product by its model number and full serial number. With this information, the Keysight representative can determine whether your product is still within its warranty period.

---

---

## Getting Prepared

---

**CAUTION** The PNA contains extremely sensitive components that can be ruined if mishandled. Follow instructions carefully when making cable connections, especially wire harness connections.

The person performing the work accepts responsibility for the full cost of the repair or replacement of damaged components.

---

To successfully install this upgrade kit, you will need the following:

- A license key - refer to “[License Key Redemption](#)” below.
- A PDF copy or a paper copy of the PNA Service Guide - refer to “[Downloading the Online PNA Service Guide](#)” below.
- An ESD-safe work area - refer to “[Protecting Your Workspace from Electrostatic Discharge](#)” below.
- Correct tools - refer to “[Tools Required for the Installation](#)” on page 5.
- Enough time - refer to “[About Installing the Upgrade](#)” on page 6.
- Test equipment for the post-upgrade adjustments and full instrument calibration. To view the equipment list, click the Chapter 3 bookmark “[Tests and Adjustments](#)” in the PDF Service Guide<sup>1</sup>.

## License Key Redemption

---

**NOTE** The enclosed Option Entitlement Certificate is a receipt, verifying that you have purchased a licensed option for the PNA of your choice. You must now use a Keysight Web page to request a license key for the instrument that will receive the option.

---

To enable the option product, you must request a license key from: <http://www.keysight.com/find/softwarelicense>. To complete the request, you will need to gather the following information:

- From the certificate
  - Order number
  - Certificate number
- From your instrument
  - Model number
  - Serial number
  - Host ID

The instrument information is available on the network analyzer – on the analyzer’s **Help** menu, click **About Network Analyzer**.

If you provide an email address, Keysight will promptly email your license key. Otherwise, you will your receive your license key via postal mail.

---

1. See “[Downloading the Online PNA Service Guide](#)” on page 5.

## Downloading the Online PNA Service Guide

To view the online Service Guide for your PNA model number, use the following steps:

1. Go to [www.keysight.com](http://www.keysight.com).
2. In the Search box, enter the model number of the analyzer (Ex: N5222A) and click **Search**.
3. Click **Technical Support > Manuals**.
4. Click **Service Manual**.
5. Click the service guide title to download the PDF file.
6. When the PDF of the Service Guide is displayed, scroll through the Contents section bookmarks to locate the information needed.

## Protecting Your Workspace from Electrostatic Discharge

For information, click on the Chapter 1 bookmark, "Electrostatic Discharge Protection" in the PDF Service Guide<sup>1</sup>.

### ESD Equipment Required for the Installation

Description	Keysight Part Number
ESD grounding wrist strap	9300-1367
5-ft grounding cord for wrist strap	9300-0980
2 x 4 ft conductive table mat and 15-ft grounding wire	9300-0797
ESD heel strap (for use with conductive floors)	9300-1308

### Tools Required for the Installation

Description	Qty	Part Number
T-6 TORX driver - set to 4 in-lbs (0.45 N.m)	1	N/A
T-10 TORX driver - set to 9 in-lbs (1.02 N.m)	1	N/A
T-20 TORX driver - set to 21 in-lbs (2.38 N.m)	1	N/A
5/16-in (8 mm) nutsetter or open end torque wrench - set to 10 in-lbs (1.13 N.m)	1	N/A
5/16-in (8 mm) nutsetter or open end torque wrench - set to 21 in-lbs (2.38 N.m)	1	N/A
3/16-in (5 mm) nutsetter or open end torque wrench - set to 6 in-lbs (0.68 N.m)	1	N/A
5/8-in (16 mm) nutsetter or open end torque wrench - set to 21 in-lbs (2.38 N.m)	1	N/A
1-in (25.4 mm) torque wrench - set to 72 in-lbs (8.15 N.m)	1	N/A

---

**CAUTION** Use a 5/16-in torque wrench set to 10 in-lbs on all cable connections except the front and rear panel bulkhead connectors. On these, use a 5/16-in (8 mm) nutsetter or open end torque wrench set to 21 in-lb.

---

### About Installing the Upgrade

Products affected . . . . .	N5221A and N5222A Option 219
Installation to be performed by . . . . .	Keysight service center or personnel qualified by Keysight
Estimated installation time . . . . .	5 hours
Estimated adjustment time . . . . .	0.5 hours
Estimated full instrument calibration time . . . . .	4.5 hours

## Items Included in the Upgrade Kit

Check the contents of your kit against the following list. If any part is missing or damaged, contact Keysight Technologies. Refer to [“Getting Assistance from Keysight”](#) on page 3.

**Table 1 Contents of Upgrade Kit N5222-60114**

Ref Desig.	Description	Qty	Part Number
-	Installation note (this document)	1	N5222-90124
A8	26.5 GHz source (2) board	1	5087-7342
A13	13.5 GHz (source 2) synthesizer board	1	N5240-60074 Was N5242-60150
A22	Splitter	1	5087-7139
A24	Mixer brick (2)	1	5087-7829 Was 5087-7766
A26	Test port 3 receiver coupler	2	5087-7757
A27	Test port 4 receiver coupler		
A30	Test port 3 coupler	2	5087-7813
A31	Test port 4 coupler		
A35	Test port 3 source attenuator	2	33321-60077
A36	Test port 4 source attenuator		
A39	Test port 3 bias tee (includes wire harness)	2	5067-4865
A40	Test port 4 bias tee (includes wire harness)		
A43	Test port 3 receiver attenuator	2	33321-60078
A44	Test port 4 receiver attenuator		
-	Front frame, 4-port	1	N5247-20141
-	Machine screw, M2.5 x 20, pan head (to attach A26 and A27 receiver coupler assemblies to test set deck; to attach attenuator assemblies to test set deck)	11	0515-0430
-	Machine screw, M4.0 x 10, pan head (to attach the following boards to the analyzer chassis: A13 13.5 GHz synthesizer board and A8 26.5 GHz source board.)	5	0515-0380
-	Machine screw, M3.0 x 6, flat head (to attach front frame to coupler plate)	3	0515-1946
-	Machine screw, M3.0 x 14, pan head (to attach bias tee to bracket)	6	0515-0665
-	Machine screw, M3 x 14, pan head (to attach splitter to mixer brick)	3	0515-2994
-	Machine screw, M3 x 8, pan head (to attach attenuator to bracket)	8	0515-0372
-	Machine screw, M3.0 x 20, pan head (to attach brackets to receiver couplers; to attach A24 mixer brick to block)	9	0515-1410
-	Front panel overlay (label), 4-port	1	N5222-80006
-	Keypad overlay (label)	1	N5242-80005
-	Nameplate, N5221A	1	N5221-80005
-	Nameplate, N5222A	1	N5222-80001
-	Dust caps for test ports	4	1401-0214
-	Power button overlay (label)	1	N5242-80007



**Table 1 Contents of Upgrade Kit N5222-60114**

Ref Desig.	Description	Qty	Part Number
-	Test set front plate, 4-port	1	N5221-00007
-	Gap pad (between each test coupler and the test set front plate)	4	E4403-20033
-	Short, installed on A24 mixer brick	1	0960-0055
-	Vibration mount (between couplers 1 & 3, and 2 & 4)	2	0460-2725
-	Mounting nuts (for port 3 & 4 test port couplers)	2	5022-1087
-	Cable guard, center jumper cables	1	N5242-00030
-	Cable clamp	6	1400-1334
-	Cable tie	7	1400-0249
-	Bracket for receiver coupler	2	N5242-00006
-	Bracket for attenuator assemblies	2	N5242-00007
--	Bulkhead connector for test set front plate (hardware supplied with connector)	12	1250-3805
W2	RF cable, 13.5 GHz (source 2) synthesizer board J1207 to A8 26.5 GHz source (2) board P1	1	N5222-20090
W5	RF cable, A8 source (2) board P5 to W6 on bottom of analyzer	1	N5222-20062
W6	RF cable, W5 to A26 port 3 receiver coupler	1	N5222-20041
W7	RF cable, A8 source (2) board P3 to W8 on bottom of analyzer	1	N5222-20063
W8	RF cable, W7 to A23 port 4 receiver coupler	1	N5222-20042
W14	RF cable, A29 port 1 coupler to front-panel Port 1 CPLR ARM	1	N5222-20030
W17	RF cable, A26 port 3 receiver coupler to front-panel REF 3 SOURCE OUT	1	N5222-20023
W18	RF cable, A30 port 3 coupler to front-panel Port 3 CPLR ARM	1	N5222-20015
W21	RF cable, A23 port 4 receiver coupler to front-panel REF 4 SOURCE OUT	1	N5222-20025
W22	RF cable, A31 port 4 coupler to front-panel Port 4 CPLR ARM	1	N5222-20018
W26	RF cable, A32 port 2 coupler to front-panel Port 2 CPLR ARM	1	N5222-20034
W30	RF cable, Front panel jumper	6	N5222-20091
W42	RF cable, A21 HMA26.5 to A22 splitter	1	N5222-20009
W43	RF cable, A22 splitter to A23 mixer brick	1	N5222-20007
W44	RF cable, A22 splitter to A24 mixer brick	1	N5222-20008
W48	RF cable, A33 reference mixer switch to A23 mixer brick (R1)	1	N5222-20101
W49	RF cable, REF 3 RCVR R3 IN to A24 mixer brick (R3)	1	N5222-20024
W50	RF cable, REF 4 RCVR R4 IN to A24 mixer brick (R4)	1	N5222-20027
W52	RF cable, A23 mixer brick (R1) to A20 IF multiplexer (P411)	1	N5242-60021
W53	RF cable, A23 mixer brick (R2) to A20 IF multiplexer (P412)	1	N5242-60022
W55	RF cable, A24 mixer brick (D) to A20 IF multiplexer (P801)	1	N5242-60024
W56	RF cable, A24 mixer brick (R4) to A20 IF multiplexer (P414)	1	N5242-60019
W57	RF cable, A24 mixer brick (R3) to A20 IF multiplexer (P413)	1	N5242-60020
W58	RF cable, A24 mixer brick (C) to A20 IF multiplexer (P601)	1	N5242-60023
W60	RF cable, A20 IF multiplexer board P203 to A12 SPAM board (J2)	1	N5242-60013

**Table 1 Contents of Upgrade Kit N5222-60114**

Ref Desig.	Description	Qty	Part Number
W62	RF cable, A20 IF multiplexer board P603 to A12 SPAM board (J5)	1	N5242-60015
W67	RF cable, A10 frequency reference board J7 to bottom of A13 13.5 GHz (source 2) synthesizer board J5 (4-port only)	1	N5242-60030
W74	RF cable, A38 port 1 bias tee to A29 port 1 coupler	1	N5222-20012
W75	RF cable, A26 port 3 receiver coupler to A35 port 3 source attenuator	1	N5222-20002
W76	RF cable, A35 port 3 source attenuator to front-panel Port 3 SOURCE OUT	1	N5222-20019
W77	RF cable, Port 3 CPLR THRU to A39 port 3 bias tee	1	N5222-20016
W78	RF cable, A39 port 3 bias tee to A30 port 3 coupler	1	N5222-20011
W79	RF cable, A27 port 4 receiver coupler to A36 port 4 source attenuator	1	N5222-20001
W80	RF cable, A36 port 4 source attenuator to front-panel Port 4 SOURCE OUT	1	N5222-20020
W81	RF cable, Port 4 CPLR THRU to A40 port 4 bias tee	1	N5222-20017
W82	RF cable, A40 port 4 bias tee to A31 port 4 coupler	1	N5222-20014
W86	RF cable, A41 port 2 bias tee to A32 port 2 coupler	1	N5222-20013
W89	RF cable, Port 3 RCVR C IN to A43 port 3 receiver attenuator	1	N5222-20021
W90	RF cable, A43 port 3 receiver attenuator to A24 mixer brick (C)	1	N5222-20006
W91	RF cable, Port 4 RCVR D IN to A44 port 4 receiver attenuator	1	N5222-20022
W92	RF cable, A44 port 4 receiver attenuator to A24 mixer brick (D)	1	N5222-20026
-	Ribbon cable, A19 test set motherboard J213 to A24 mixer brick (2)	1	N5242-60006
-	Ribbon cable, A19 test set motherboard J206 to A43 port 3 receiver attenuator	1	8121-0982 Was N5242-60007
-	Ribbon cable, A19 test set motherboard J207 to A44 port 4 receiver attenuator	1	8121-0982 Was N5242-60007
-	Ribbon cable, A19 test set motherboard J202 to A35 port 3 source attenuator	1	N5242-60008
-	Ribbon cable, A19 test set motherboard J203 to A36 port 4 source attenuator	1	N5242-60008

---

**NOTE** Extra quantities of items such as protective plastic caps, screws, cable ties, and cable clamps may be included in this upgrade kit. It is normal for some of these items to remain unused after the upgrade is completed.

---

---

## Installation Procedure for the Upgrade

The network analyzer must be in proper working condition prior to installing this option. Any necessary repairs must be made before proceeding with this installation.

---

**WARNING**      **This installation requires the removal of the analyzer's protective outer covers. The analyzer must be powered down and disconnected from the mains supply before performing this procedure.**

---

### Overview of the Installation Procedure

Step 1. Obtain a Keyword and Verify the Information.

Step 2. Remove the Outer Cover.

Step 3. Remove the Inner Cover.

Step 4. Remove the Front Panel Assembly.

Step 5. Remove the A23 Test Set Motherboard.

Step 6. Remove Some Bottom-Side (Test Set) Cables.

Step 7. Remove the A23 Mixer Brick Assembly.

Step 8. Assemble the A24 Mixer Brick Assembly.

Step 9. Assemble the A26 and A27 Receiver Coupler Assemblies.

Step 10. Install the A23/A24 Mixer Brick Block Assembly.

Step 11. Install the A26 and A27 Receiver Coupler Assemblies.

Step 12. Assemble the A35 and A36 Source Attenuators and the A43 and A44 Receiver Attenuators.

Step 13. Install the A39 and A40 Bias Tees, A35 and A36 Source Attenuators, and the A43 and A44 Receiver Attenuators.

Step 14. Assemble the A29 - A32 Test Port Coupler Assemblies.

Step 15. Install the LED Boards, Bulkhead Connectors, and Test Port Coupler Assemblies to the 4-Port Test Set Front Plate.

Step 16. Install the Bulkhead Connectors in the Test Set Front Plate.

Step 17. Install the 4-Port Coupler Plate Assembly to the Deck.

Step 18. Assemble the A8 26.5 GHz Source 2 Assembly.

Step 19. Install the A8 26.5 GHz Source 2 Assembly.

Step 20. Install the A13 13.5 GHz (Source 2) Synthesizer Board and Cables.

Step 21. Install the Test Set Cables.

Step 22. Reinstall the A19 Test Set Motherboard.

Step 23. Install Cables on the A19 Test Set Motherboard.

Step 24. Replace the Front Frame in the Front Panel Assembly.

Step 25. Reinstall Front Panel Assembly.

Step 26. Install the Overlays.

Step 27. Install the Front Panel Jumper Cables.

Step 28. Position the Cables and Wires to Prevent Pinching.

Step 29. Reinstall the Inner Cover.

Step 30. Reinstall the Outer Cover.

Step 31. Remove Option 219 License.

Step 32. Enable Options P04 (400) and 419.

Step 33. Perform Post-Upgrade Adjustments and Calibration.

Step 34. Prepare the PNA for the User.

## **Step 1. Obtain a Keyword and Verify the Information**

Follow the instructions on the Option Entitlement Certificate supplied to obtain a license key for installation of this upgrade. Refer to [“License Key Redemption” on page 4](#).

Verify that the model number, serial number, and option number information on the license key match those of the instrument on which this upgrade will be installed.

If the model number, serial number, or option number do not match those on your license key, you will not be able to install the option. If this is the case, contact Keysight for assistance before beginning the installation of this upgrade. Refer to [“Contacting Keysight” on page 3](#).

Once the license key has been received and the information verified, you can proceed with the installation at step 2.

## **Step 2. Remove the Outer Cover**

For instructions, click the Chapter 7 bookmark “Removing the Covers” in the PDF Service Guide<sup>1</sup>.

## **Step 3. Remove the Inner Cover**

For instructions, click the Chapter 7 bookmark “Removing the Covers” in the PDF Service Guide<sup>1</sup>.

## **Step 4. Remove the Front Panel Assembly**

For instructions, click the Chapter 7 bookmark “Removing and Replacing the Front Panel Assembly” in the PDF Service Guide<sup>1</sup>.

## **Step 5. Remove the A23 Test Set Motherboard**

For instructions, click the Chapter 7 bookmark “Removing and Replacing the A23 test set motherboard” in the

---

1. See [“Downloading the Online PNA Service Guide” on page 5](#).

## Step 6. Remove Some Bottom-Side (Test Set) Cables

---

**CAUTION** Be careful not to damage the center pins of the semirigid cables. Some flexing of the cables may be necessary but do not over-bend them.

---

---

**NOTE** When removing a cable, also remove the plastic cable clamp, if present. It is normal for some of the cable clamp's adhesive to remain.

---

1. Place the analyzer bottom-side up on a flat surface.
2. Remove the following cables in the order listed. To see an image showing the location of these cables, click the Chapter 6 bookmark "Bottom RF Cables, Standard 4-Port Configuration, Option 219" in the PDF Service Guide<sup>1</sup>.

These cables may be discarded - they will not be reinstalled.

- W42 (N5222-20073) A21 HMA26.5 to A23 mixer brick
- W48 (N5222-20003) A33 reference mixer switch to A23 mixer brick (R1)
- W74 (N5222-20072) A38 port 1 bias tee to A29 port 1 coupler
- W14 (N5222-20070) A29 port 1 coupler to front-panel Port 1 CPLR ARM
- W66 (N5222-20065) A41 port 2 bias tee to A32 port 2 coupler
- W26 (N5222-20071) A32 port 2 coupler to front-panel Port 2 CPLR ARM

These cables must be saved - they will be reinstalled.

- W4 (N5222-20040) W3 to A25 port 1 receiver coupler
- W10 (N5222-20043) W9 to A24 port 2 receiver coupler
- W88 (N5222-20004) A42 port 1 receiver attenuator to A23 mixer brick (A)
- W13 (N5222-20005) A25 port 1 receiver coupler to A33 reference mixer switch
- W35 (N5222-20033) A33 reference mixer switch to front-panel REF 1 SOURCE OUT
- W36 (N5222-20032) REF 1 RCVR R1 IN to A33 reference mixer switch
- W30 (N5222-20091) (qty = 6) Front panel jumper

**NOTE:** Remove and save the cable guards for the front panel jumpers.

## Step 7. Remove the A23 Mixer Brick Assembly

Remove the A23 mixer brick assembly from the PNA. For instructions, click the Chapter 7 bookmark, "Removing and Replacing the A23 and A24 Mixer Bricks" in the PDF Service Guide<sup>1</sup>.

---

1. See ["Downloading the Online PNA Service Guide"](#) on page 5.

## Step 8. Assemble the A24 Mixer Brick Assembly

1. Follow the instruction shown in [Figure 1](#) and [Figure 2](#). New parts are listed in [Table 1 on page 7](#) of this document.

**Figure 1** A24 Mixer Brick Assembly

- ① Install mixer 5087-7829 to mounting block. Hand start 3x screws 0515-1410. Do not tighten.
- ② Install 2x screws 0515-0372. Torque to 9 in-lbs.
- ③ Torque screws installed in step 1 to 9 in-lbs.

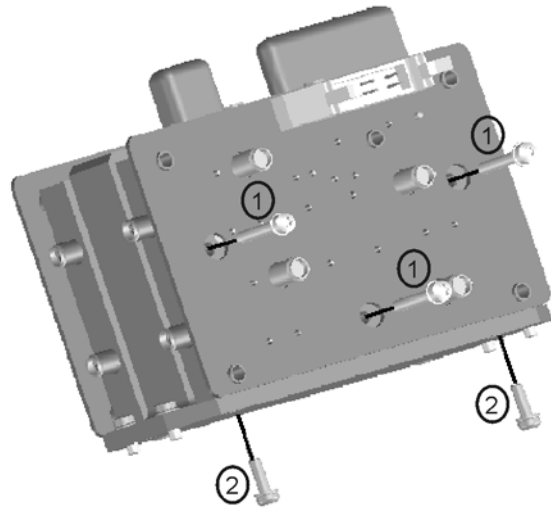

N5222\_120\_03

**Figure 2 A24 Mixer Brick Block Assembly (cont.)**

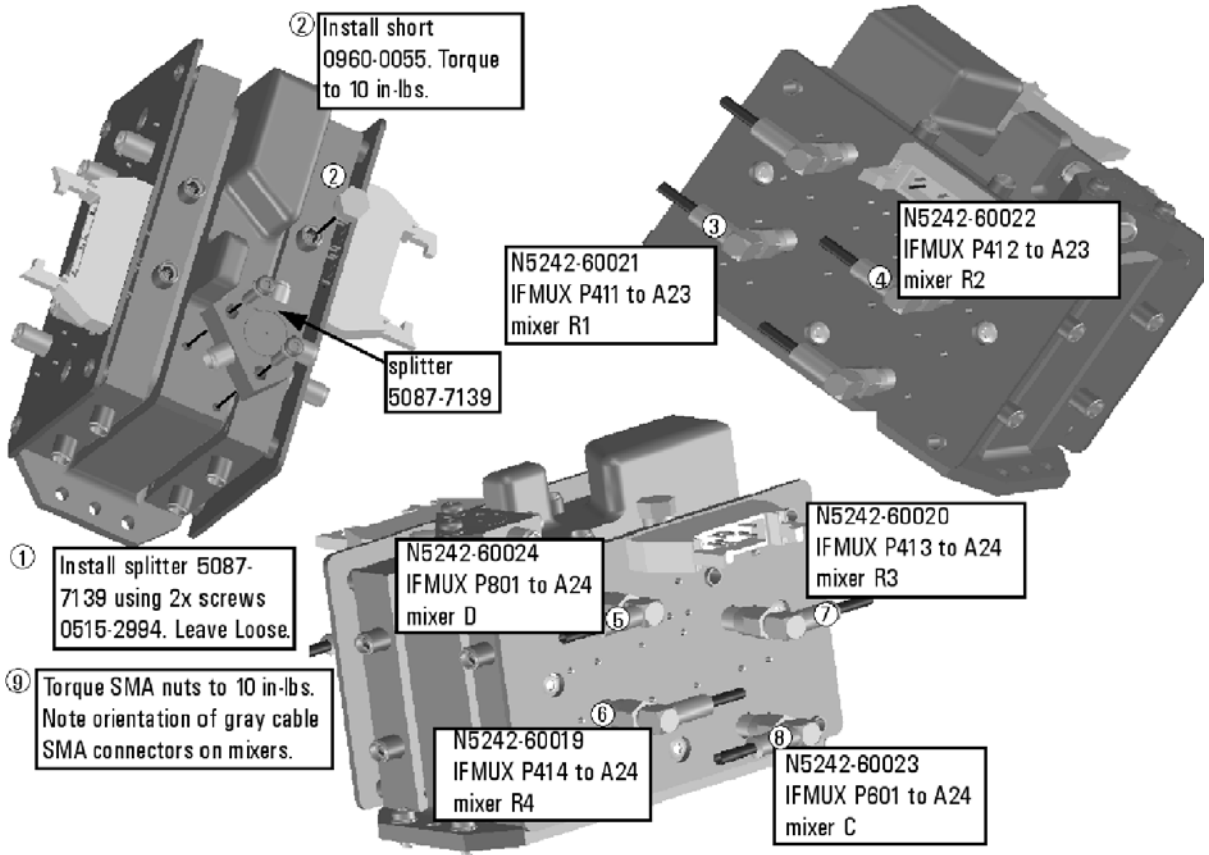

N5222\_120\_04

## Step 9. Assemble the A26 and A27 Receiver Coupler Assemblies

Follow the instructions shown in [Figure 3](#). New parts are listed in [Table 1 on page 7](#) of this document.

**Figure 3** A26 and A27 Receiver Coupler Assemblies

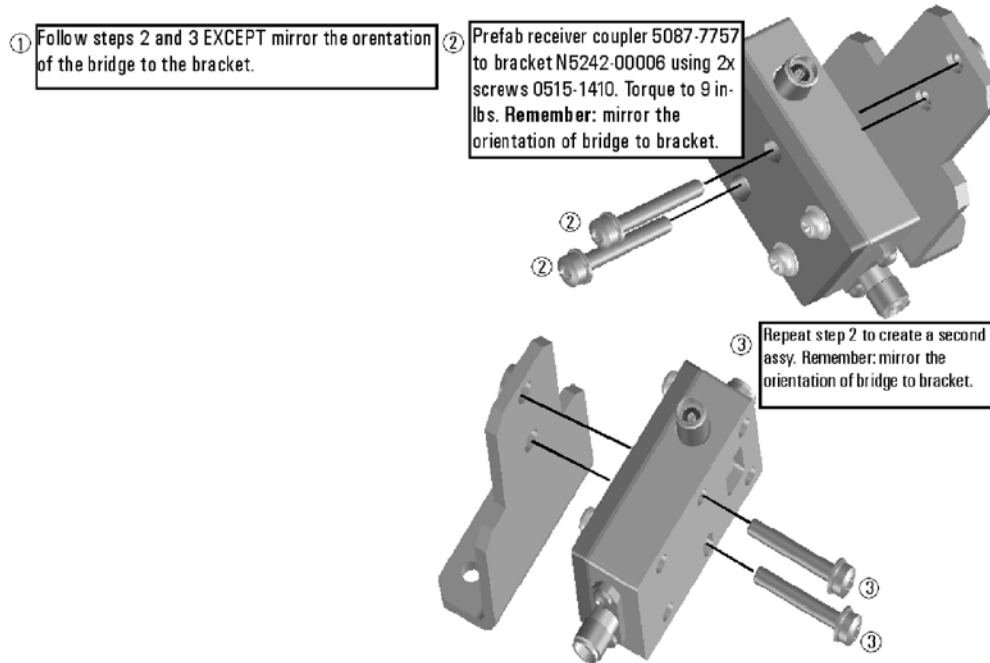

N5222\_120\_06



### Step 10. Install the A23/A24 Mixer Brick Block Assembly

Follow instruction 1 shown in [Figure 4](#). New parts are listed in [Table 1 on page 7](#) of this document.

**Figure 4** Mixer Brick Block and Receiver Coupler Assemblies Installation

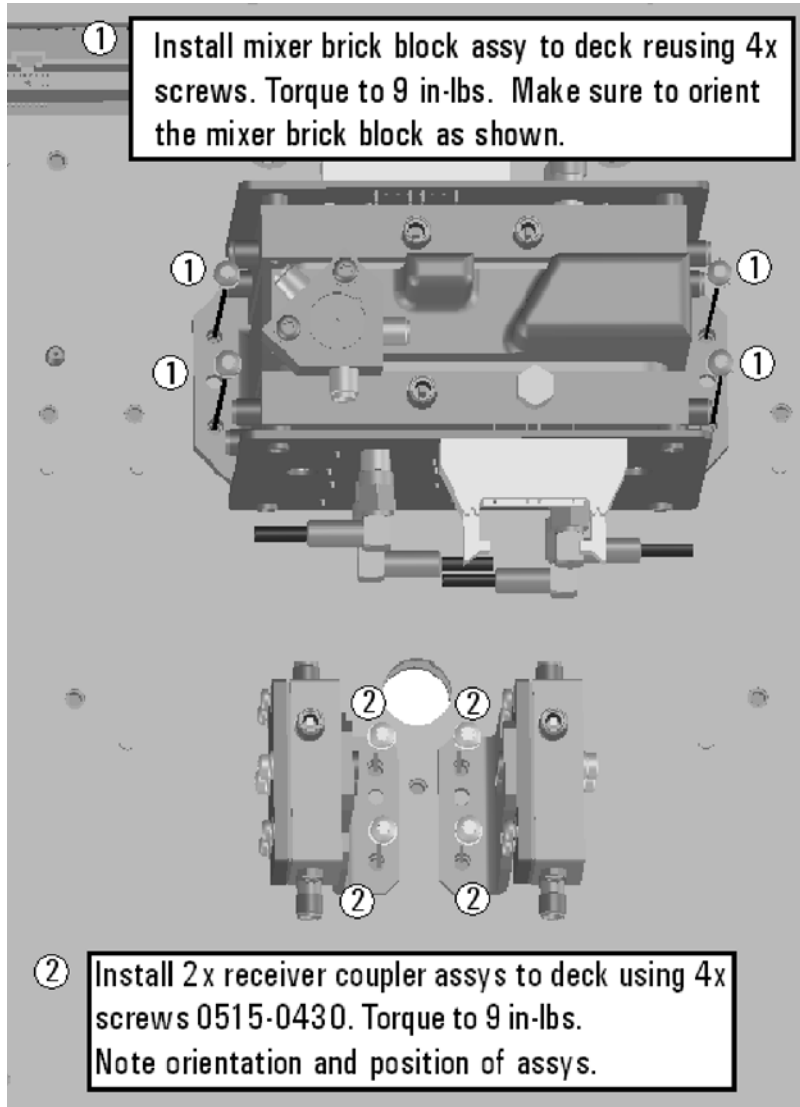

N5222\_120\_05

## Step 11. Install the A26 and A27 Receiver Coupler Assemblies

Follow instruction 2 shown in [Figure 4](#). New parts are listed in [Table 1 on page 7](#) of this document.

## Step 12. Assemble the A35 and A36 Source Attenuators and the A43 and A44 Receiver Attenuators

Follow the five instructions shown in [Figure 5](#).

**Figure 5** A35, A36 Source Attenuators Assembly and A43, A44 Receiver Attenuators Assembly

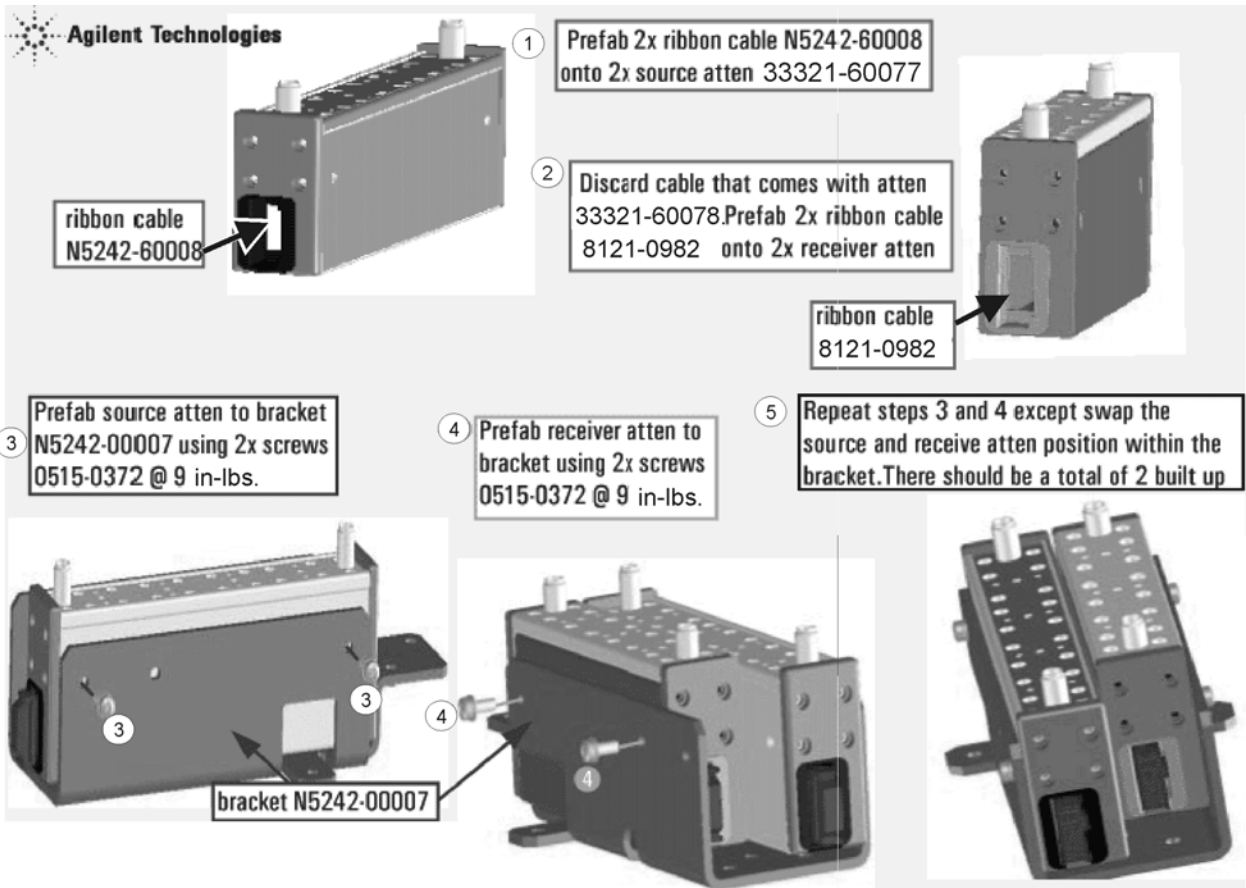

N5222\_123\_02

### Step 13. Install the A39 and A40 Bias Tees, A35 and A36 Source Attenuators, and the A43 and A44 Receiver Attenuators

Follow the instructions shown in [Figure 6](#).

**Figure 6** A39, A40 Bias Tees, A35, A36 Source Attenuators Assembly, and A43, A44 Receiver Attenuators Installation

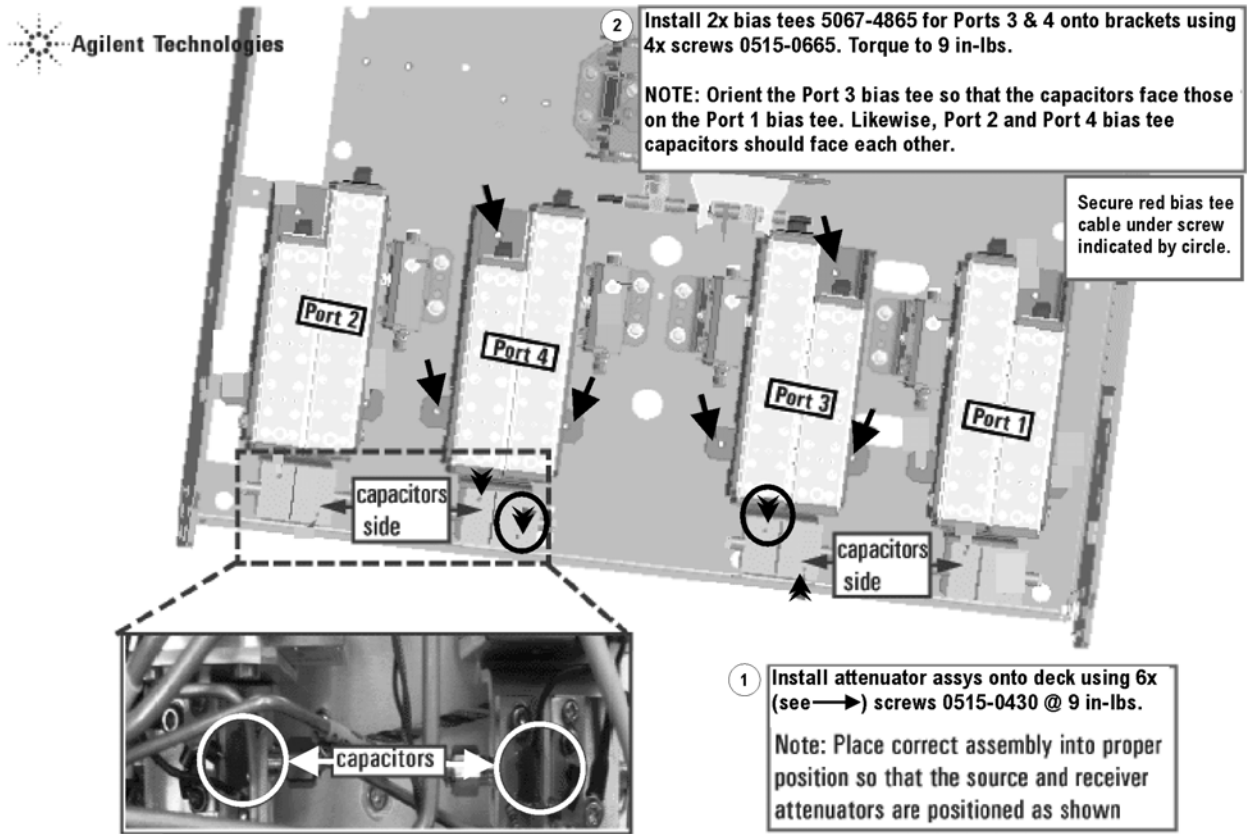

N5222\_124\_01

## Step 14. Assemble the A29 - A32 Test Port Coupler Assemblies

1. Remove the A29 test port 1 coupler and A32 test port 2 coupler from the PNA. For instructions, click the Chapter 7 bookmark, "Removing and Replacing the A29 - A32 Test Port Couplers" in the PDF Service Guide<sup>1</sup>.
2. Using pliers, remove the adhesive bumper on the A29 test port 1 coupler and on the A32 test port 2 coupler.
3. Follow the two instructions shown in [Figure 7](#). New parts are listed in [Table 1 on page 7](#) of this document.

**Figure 7** A29 - A32 Test Port Coupler Assembly

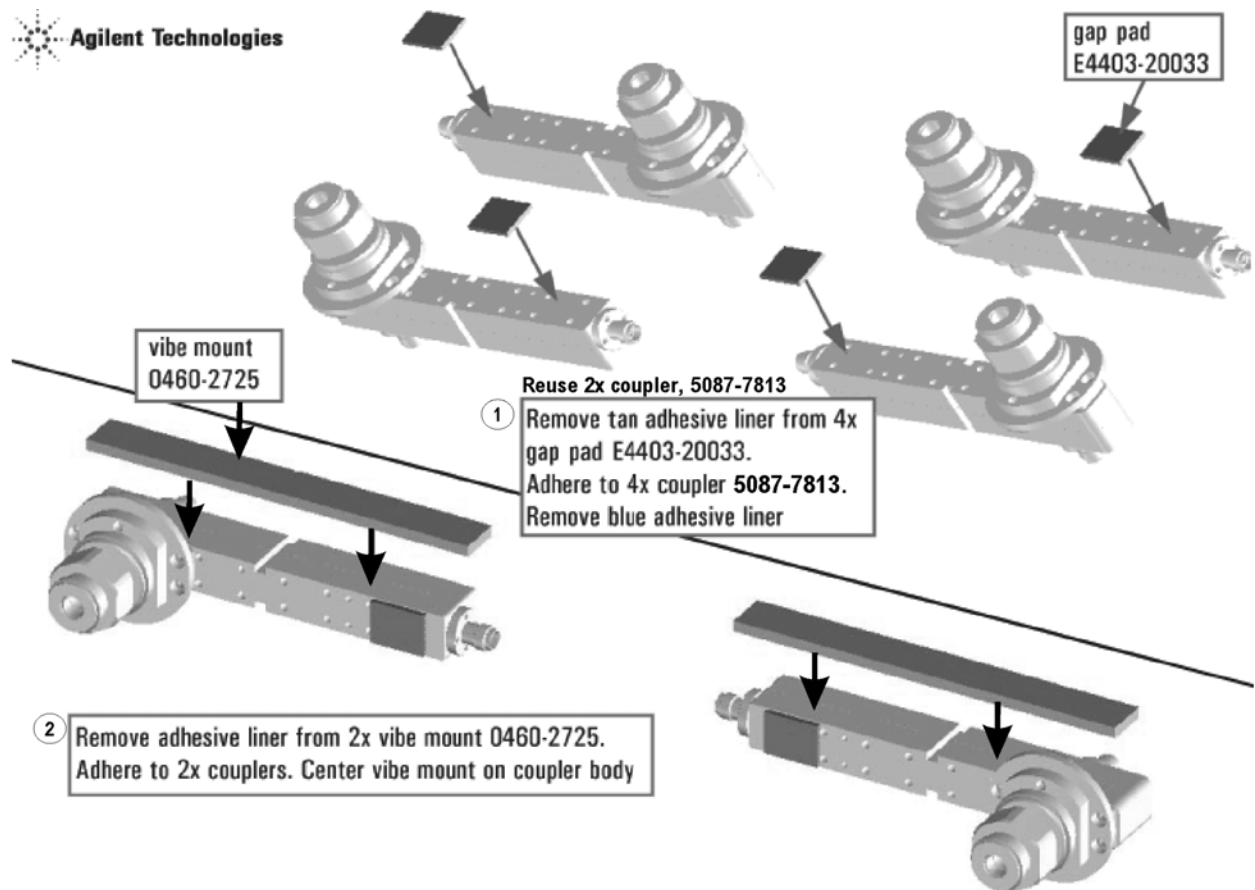

N5222\_120\_07

## Step 15. Install the LED Boards, Bulkhead Connectors, and Test Port Coupler Assemblies to the 4-Port Test Set Front Plate

1. Remove two screws from each LED board and remove the boards from the 2-port test set front plate of the PNA. Keep the screws and LED boards for reuse later.
2. Remove the 12 bulkhead connectors, nuts and washers from the 2-port front plate to reuse later.
3. Remove the 2-port test set front plate from the test set deck. Keep the screws for reuse later, but dispose of the test set front plate.
4. Follow the two instructions shown in [Figure 8](#).

**Figure 8 LED Board Assemblies and Test Port Coupler Assemblies Installation**

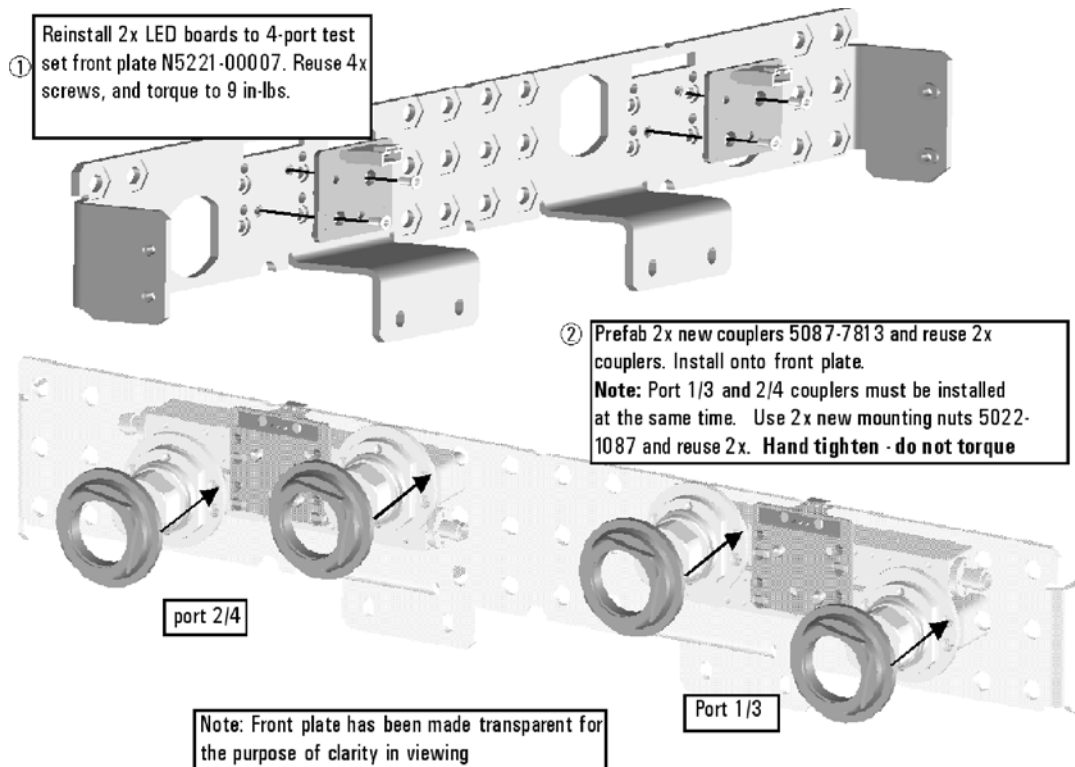

N5222\_121\_04

## Step 16. Install the Bulkhead Connectors in the Test Set Front Plate

Refer to [Figure 9](#) for this procedure. New parts are listed in [Table 1 on page 7](#).

1. Locate the bulkhead connectors you removed earlier from the 2-port test set front plate of the PNA. Use these and the new bulkhead connectors included in the kit for the remainder of this step.
2. From the back side of the test set front plate, insert a bulkhead connector into a hole in the plate.
3. Install 1x washer and 1x nut. Hand tighten nut and ensure bulkhead connector hexagon nut, on the back side of test set front plate, is aligned to the test set subpanel hexagon indent.
4. Repeat previous two steps for the remaining bulkhead connectors.
5. Torque nuts, on the front side of test set front plate, to 21 in-lbs.

**Figure 9 Bulkhead Connectors Installation**

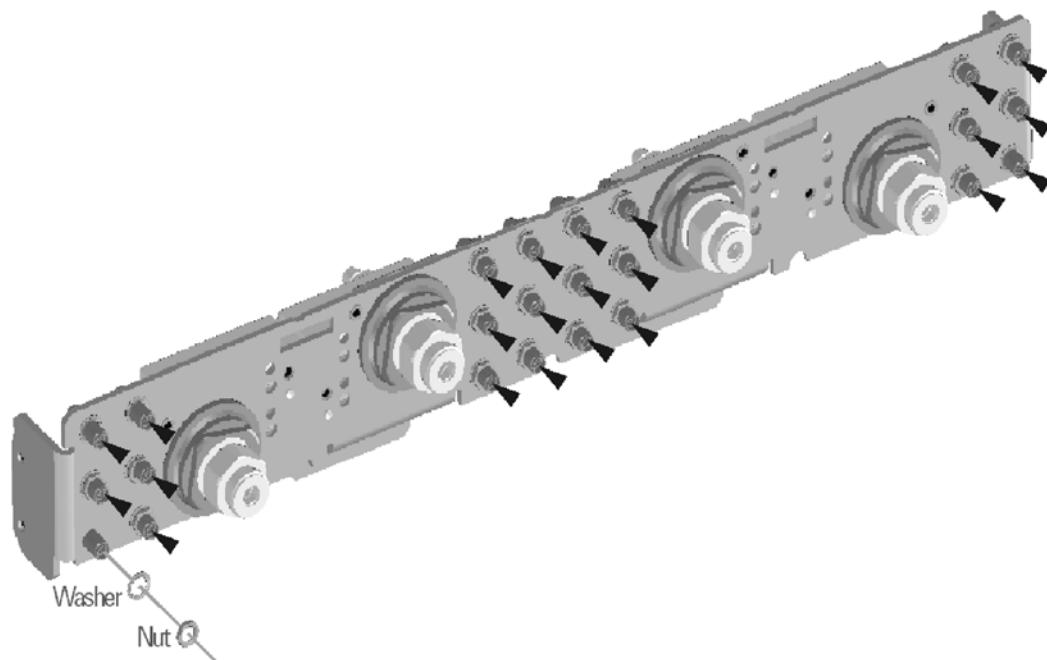

N5242\_004\_09

## Step 17. Install the 4-Port Coupler Plate Assembly to the Deck

Follow the four instructions shown in [Figure 10](#).

**Figure 10** Coupler Plate Assembly Installation

- ① Install coupler plate assy to deck. Reuse 4x screws. **Hand tighten - do not torque.**
- ② Reinstall 4x screws. Torque to 9 in-lbs. Alternate sides in torque sequence, as per the circled letters.
- ③ Torque the 4x screws in step 1 to 9 in-lbs
- ④ Torque the 4x coupler nuts to 72 in-lbs.

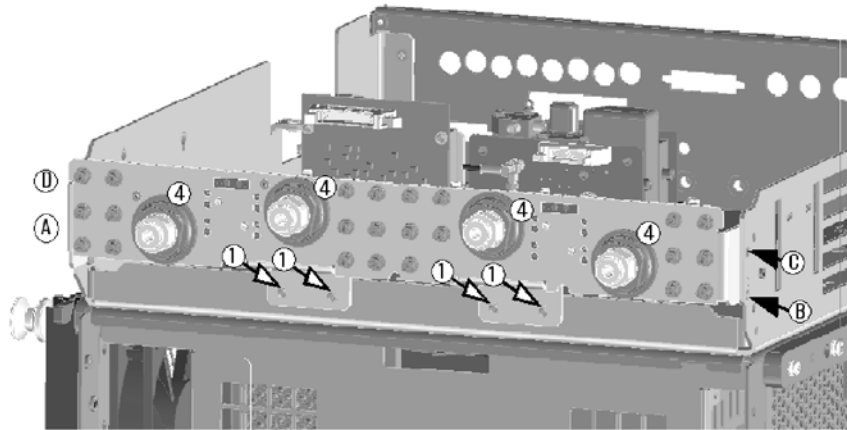

N5222 112 05

**Step 18. Assemble the A8 26.5 GHz Source 2 Assembly**

Follow the three instructions shown in **Figure 11**.

**Figure 11 A8 Source 2 Assembly**

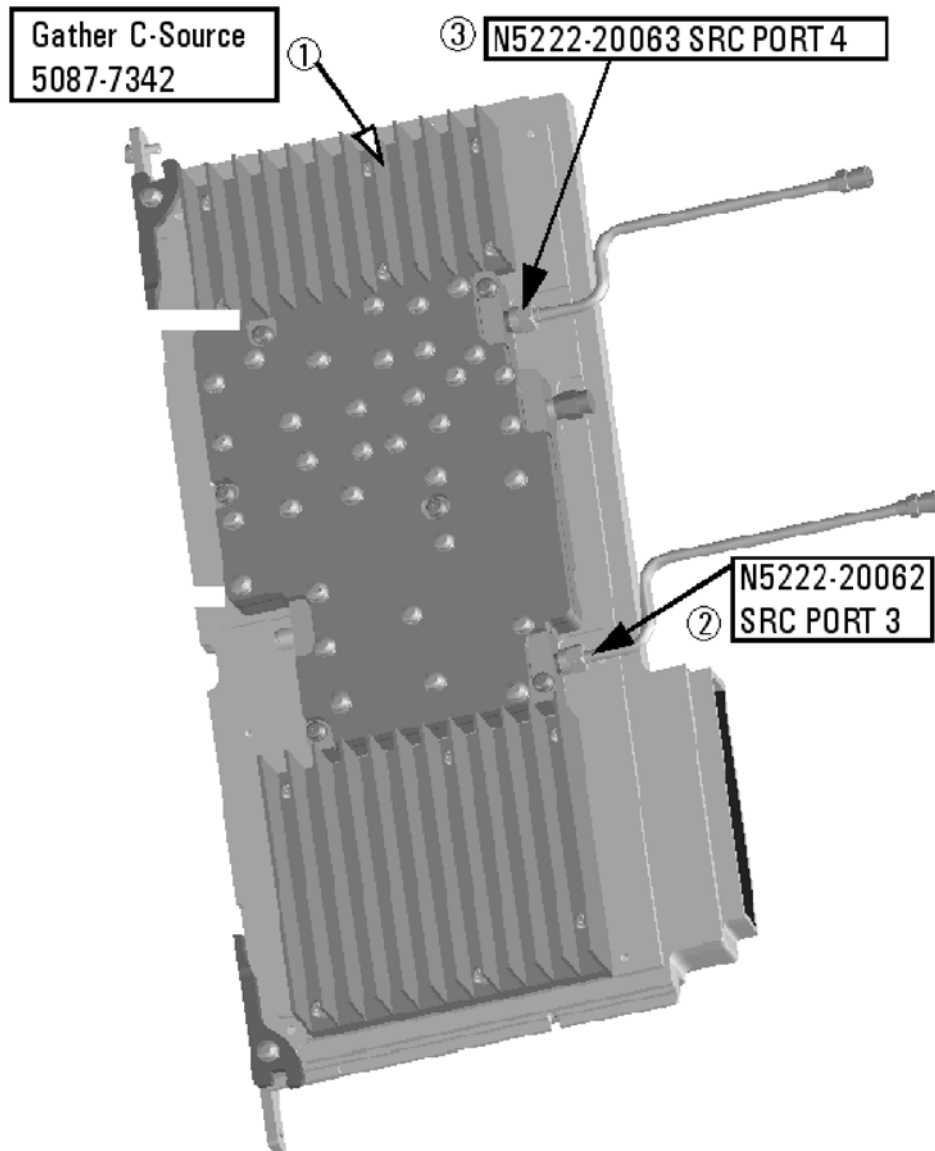

N5222\_120\_10



## Step 19. Install the A8 26.5 GHz Source 2 Assembly

Follow the three instructions shown in [Figure 12](#).

**Figure 12** A8 Source 2 Assembly Installation

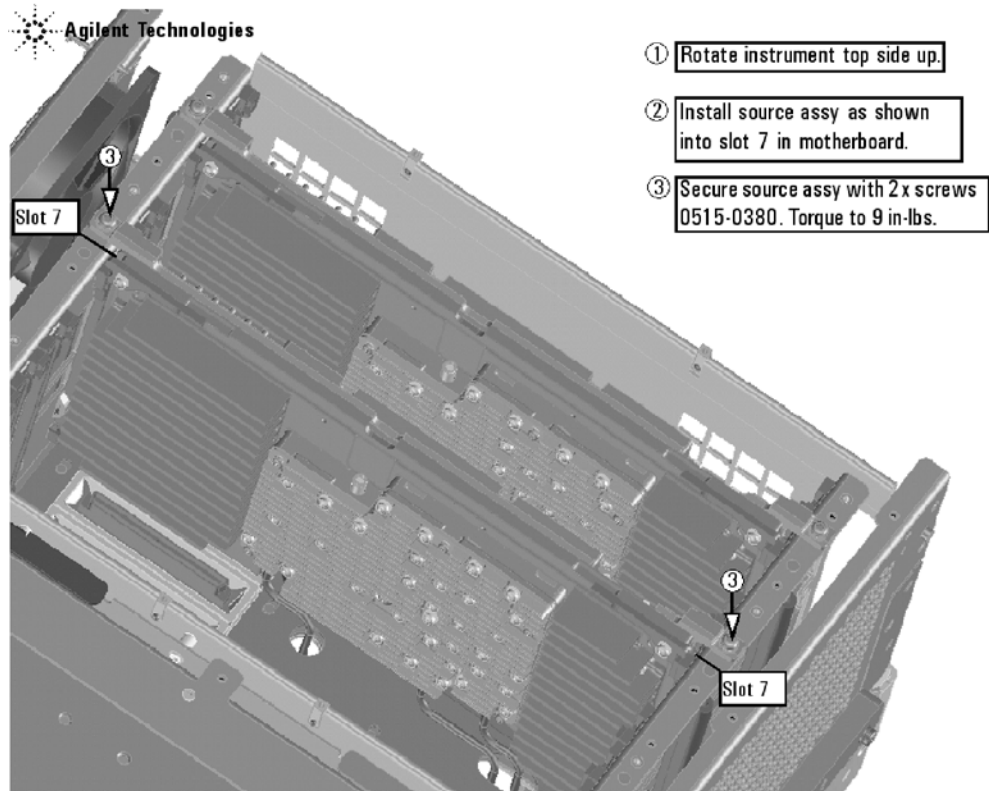

N5222\_120\_11

## **Step 20. Install the A13 13.5 GHz (Source 2) Synthesizer Board and Cables**

1. Install new gray cable W67 (N5242-60030) to connector J5 of the new A13 (source 2) synthesizer board (N5240-60074). The loose end of the cable will be connected on the A10 frequency reference board (J7) after the A13 board has been installed in the analyzer.
2. Install the A13 board into slot 2 in the motherboard. Secure the board into the chassis using two screws (0515-0380). To see an image showing the location of the A13 board in the motherboard, click the Chapter 6 bookmark "Top Assemblies, All Options" in the PDF Service Guide<sup>1</sup>.
3. Connect cable W2 (N5222-20090) between the A8 source 2 board and the A13 (source 2) synthesizer board. Tighten the cable connectors to 10 in-lbs using a 5/16-in torque wrench.
4. Connect the loose end of new gray flex cable W67 (N5242-60030) on the A10 frequency reference board (J7). (The other end of this cable was previously connected to J5 of the A13 (source 2) synthesizer board.)

---

1. See ["Downloading the Online PNA Service Guide"](#) on page 5.

## Step 21. Install the Test Set Cables

---

**CAUTION** Use a 5/16-in torque wrench set to 10 in-lbs on all cable connections except the front and rear panel bulkhead connectors. Torque these connections to 21 in-lb.

---

---

**CAUTION** Follow instructions carefully when making cable connections, especially wire harness connections. Incorrect connections can destroy components, resulting in additional customer costs.

---

### Flexible Cables Required for Upgrading to an Option 419 PNA

Install the following gray flexible cables in the order listed. To see images showing the location of these cables, click either of the Chapter 6 bookmarks “Bottom RF Cables, 4-Port, Option 419” in the PDF Service Guide<sup>1</sup>. New parts are listed in [Table 1 on page 7](#).

- W60 (N5242-60013) A20 IF multiplexer board P203 to A12 SPAM board J2
- W62 (N5242-60015) A20 IF multiplexer board P603 to A12 SPAM board J5

If the following cables were not connected when the new mixer brick assembly was installed earlier, connect them now:

- W52 (N5242-60021) A23 mixer brick (R1) to A20 IF multiplexer (P411)
- W53 (N5242-60022) A23 mixer brick (R2) to A20 IF multiplexer (P412)
- W55 (N5242-60024) A24 mixer brick (D) to A20 IF multiplexer (P801)
- W56 (N5242-60019) A24 mixer brick (R4) to A20 IF multiplexer (P414)
- W57 (N5242-60020) A24 mixer brick (R3) to A20 IF multiplexer (P413)
- W58 (N5242-60023) A24 mixer brick (C) to A20 IF multiplexer (P601)

### Semirigid Cables Required for Upgrading to an Option 419 PNA

To see images showing the location of these cables, click the Chapter 6 bookmark “Bottom RF Cables, 4-Port, Option 419” in the PDF Service Guide<sup>1</sup>. New parts are listed in [Table 1 on page 7](#).

---

**NOTE** Use a 5/16” wrench to hold cable connectors when tightening a mating semi-rigid cable.

---

- W26 (N5222-20034) A32 port 2 coupler to front-panel Port 2 CPLR ARM
- W82 (N5222-20014) A40 port 4 bias tee to A31 port 4 coupler
- W91 (N5222-20022) Port 4 RCVR D IN to A44 port 4 receiver attenuator
- W81 (N5222-20017) Port 4 CPLR THRU to A40 port 4 bias tee
- W86 (N5222-20013) A41 port 2 bias tee to A32 port 2 coupler
- W22 (N5222-20018) A31 port 4 coupler to front-panel Port 4 CPLR ARM
- W80 (N5222-20020) A36 port 4 source attenuator to front-panel Port 4 SOURCE OUT

- W50 (N5222-20027) REF 4 RCVR R4 IN to A24 mixer brick (R4)
- W92 (N5222-20026) A44 port 4 receiver attenuator to A24 mixer brick (D)
- W79 (N5222-20001) A27 port 4 receiver coupler to A36 port 4 source attenuator
- W21 (N5222-20025) A27 port 4 receiver coupler to front-panel REF 4 SOURCE OUT
- W89 (N5222-20021) Port 3 RCVR C IN to A43 port 3 receiver attenuator
- W74 (N5222-20012) A38 port 1 bias tee to A29 port 1 coupler
- W77 (N5222-20016) Port 3 CPLR THRU to A39 port 3 bias tee
- W18 (N5222-20015) A30 port 3 coupler to front-panel Port 3 CPLR ARM
- W76 (N5222-20019) A35 port 3 source attenuator to front-panel Port 3 SOURCE OUT
- W12 (N5222-20045) Port 1 CPLR THRU to A29 port 1 coupler
- W14 (N5222-20030) A29 port 1 coupler to front-panel Port 1 CPLR ARM
- W78 (N5222-20011) A39 port 3 bias tee to A30 port 3 coupler

- W36 (reuse) (N5222-20032) REF 1 RCVR R1 IN to A33 reference mixer switch
- \* Refer to the note shown in **Figure 13** for information on installing W36 (part number N5222-20032).

**Figure 13 Information to Secure W35 and W36**

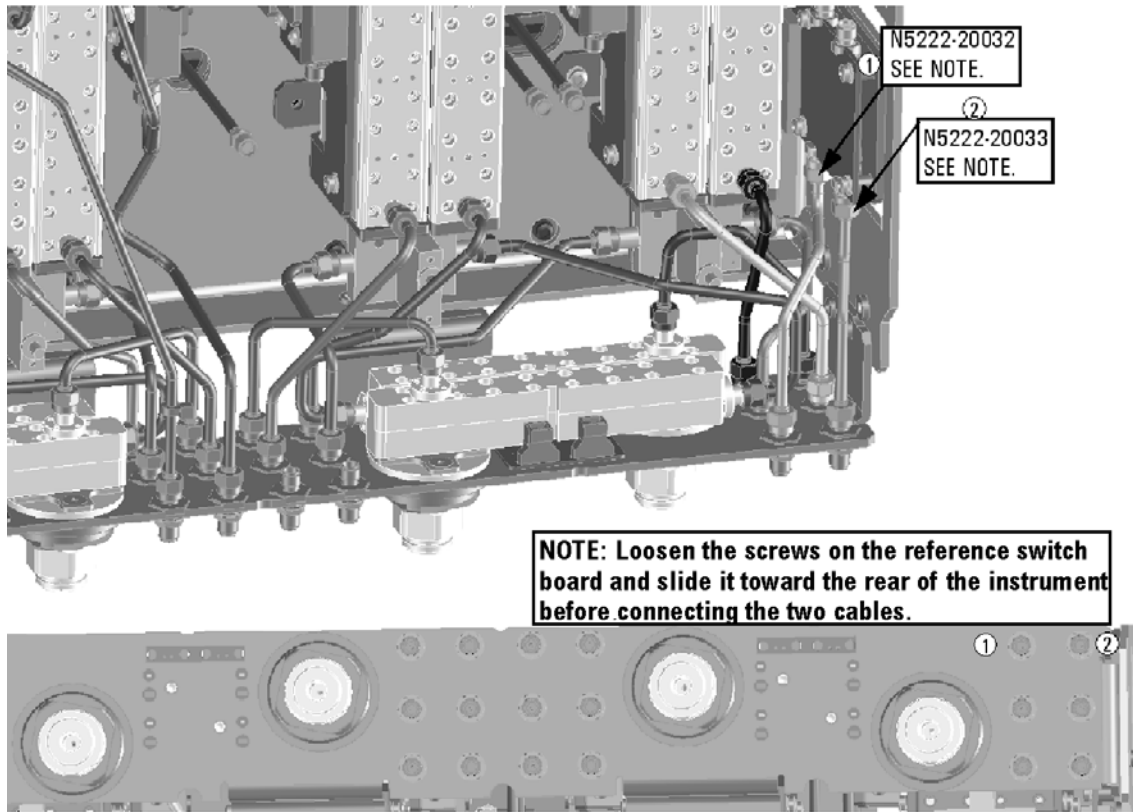

N5222\_121\_03

- W35 (reuse) (N5222-20033) A33 reference mixer switch to front-panel REF 1 SOURCE OUT
- \* Refer to the note shown in **Figure 13** for information on installing W35 (part number N5222-20033).
- W17 (N5222-20023) A26 port 3 receiver coupler to front-panel REF 3 SOURCE OUT
- W75 (N5222-20002) A26 port 3 receiver coupler to A35 port 3 source attenuator
- W90 (N5222-20006) A43 port 3 receiver attenuator to A24 mixer brick (C)
- W8 (N5222-20042) W7 to A27 port 4 receiver coupler
- W6 (N5222-20041) W5 to A26 port 3 receiver coupler

- W49 (N5222-20024) REF 3 RCVR R3 IN to A24 mixer brick (R3)  
\* As shown in **Figure 14**, install two cable clamps (part number 1400-1334) to secure W49 (part number N5222-20024).

**Figure 14** Location of Cable Clamps to Secure W49

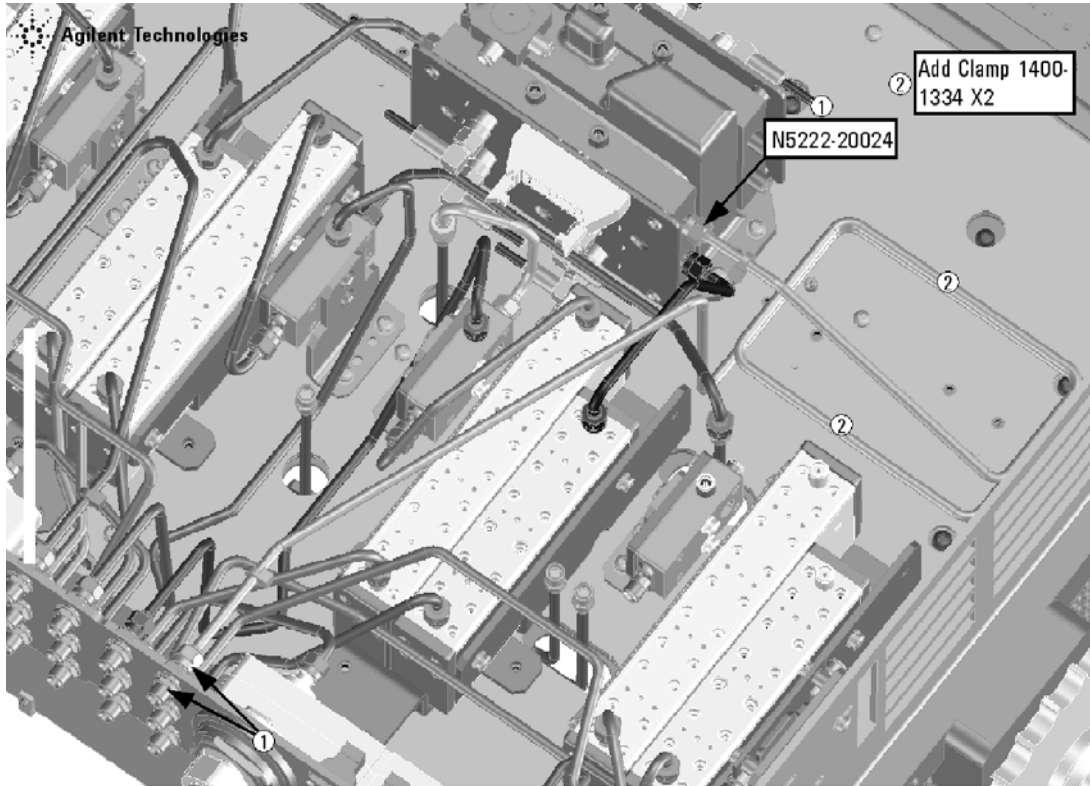

N5222\_107\_01

- W48 (N5222-20101) A33 reference mixer switch to A23 mixer brick (R1)

\* As shown in **Figure 15** on page 30, install three cable ties (part number 1400-0249) to secure W48 (part number N5222-20101).

**Figure 15** Location of Cable Ties to Secure W48

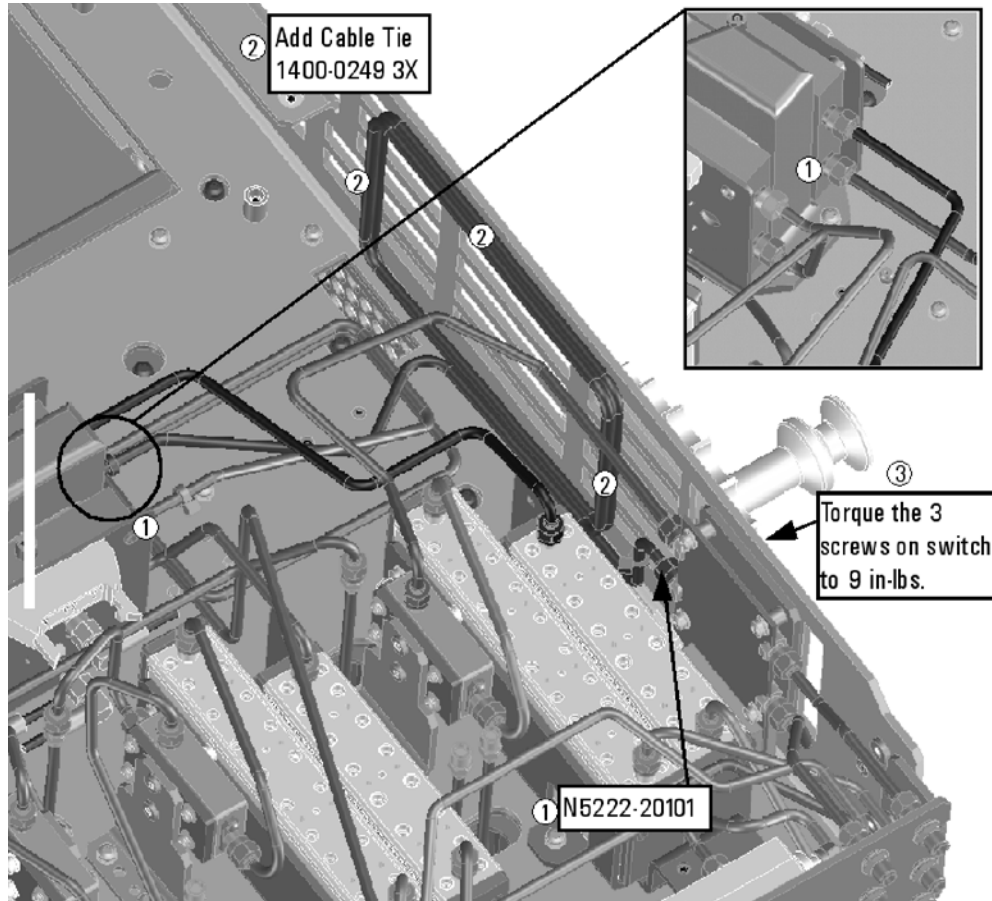

N5222\_107\_02

- W88 (reuse) (N5222-20004) A42 port 1 receiver attenuator to A23 mixer brick (A)
- W13 (reuse) (N5222-20005) A25 port 1 receiver coupler to A33 reference mixer switch

\* If the screws that attach the reference mixer switch to the test set deck were loosened, torque these screws now to 9 in-lbs.

- W10 (reuse) (N5222-20043) W9 to A28 port 2 receiver coupler
- W4 (reuse) (N5222-20040) W3 to A25 port 1 receiver coupler
- W42 (N5222-20009) A21 HMA26.5 to A22 splitter  
**NOTE:** Tighten both screws on the splitter to 9 in-lbs.
- W44 (N5222-20008) A22 splitter to A24 mixer brick
- W43 (N5222-20007) A22 splitter to A23 mixer brick

## Step 22. Reinstall the A19 Test Set Motherboard

For instructions on reinstalling the board, click the Chapter 7 bookmark “Removing and Replacing the A19 test set motherboard” in the PDF Service Guide<sup>1</sup>.

## Step 23. Install Cables on the A19 Test Set Motherboard

---

**CAUTION** Follow instructions carefully when making cable connections, especially wire harness connections. Incorrect connections can destroy components, resulting in additional customer costs.

---

Install the following ribbon cables. To see an image showing its locations, click the Chapter 6 bookmark “Bottom Ribbon Cables and Wire Harnesses, 4-Port, Option 419” in the PDF Service Guide<sup>1</sup>. New parts are listed in [Table 1 on page 7](#).

- (reuse) N5242-60006 A19 test set motherboard J212 to A23 mixer brick (1)
- N5242-60006 A19 test set motherboard J213 to A24 mixer brick (2)
- 8121-0982 A19 test set motherboard J206 to A43 port 3 receiver attenuator
- 8121-0982 A19 test set motherboard J207 to A44 port 4 receiver attenuator
- N5242-60008 A19 test set motherboard J202 to A35 port 3 source attenuator
- N5242-60008 A19 test set motherboard J203 to A36 port 4 source attenuator
- no part number A19 test set motherboard J543 to A39 port 3 bias tee
- no part number A19 test set motherboard J544 to A40 port 4 bias tee

## Step 24. Replace the Front Frame in the Front Panel Assembly

Before the front frame can be replaced, the items making up the back side of the front panel assembly must be removed. For instructions on removing these items, click the Chapter 7 bookmark “Removing and Replacing the A1-A3 and Other Front Panel Subassemblies” in the PDF Service Guide<sup>1</sup>. New parts are listed in [Table 1 on page 7](#).

1. In the section “Removing the A2 USB Board,” perform the only step.
2. In the section “Removing the A1 Front Panel Interface Board and Keypad Assembly,” perform steps 1 - 5.
3. In the section “Removing the Power Switch Board and Power Button Keypad,” perform only step 1.
4. Remove the braided gasket from the backside edges of the 2-port front frame and install it in the 4-port front frame.
5. Reassemble the front panel assembly with the new 4-port front frame (N5247-20141) by reversing the order of the instructions previously followed.

---

1. See [“Downloading the Online PNA Service Guide” on page 5](#).



## **Step 25. Reinstall Front Panel Assembly**

1. For instructions on reinstalling the front panel assembly, click the Chapter 7 bookmark “Removing and Replacing the Front Panel Assembly” in the PDF Service Guide<sup>1</sup>.
2. Be sure to install the two new screws (0515-1946) in the front panel, next to test ports 3 and 4. Torque these screws to 9 in-lbs.

## **Step 26. Install the Overlays**

To see an image of the front panel overlay (N5222-80006), keypad overlay (N5242-80005), power button overlay (N5242-80007), click the Chapter 6 bookmark “Front Panel Assembly, Front Side, All Options” in the PDF Service Guide<sup>1</sup>. New parts are listed in [Table 1 on page 7](#).

1. Remove the protective backing from the new front panel overlay (N5222-80006).
2. Loosely place the overlay in the recess on the lower front panel.
3. Placing two fingers at the middle, press the overlay firmly onto the frame while sliding your fingers in opposite directions towards the ends of the overlay. Repeat on all areas of the overlay.
4. Repeat steps 1-3 to install the keypad overlay (N5242-80005).
5. Repeat steps 1-3 to install the power button overlay (N5242-80007).

## **Step 27. Install the Front Panel Jumper Cables**

Install twelve W30 front panel jumper cables (N5222-20091) - use 6 new jumpers and reuse 6 old jumpers. To see an image of the front panel jumper cables, click the Chapter 7 bookmark “Removing and Replacing the Front Panel Assembly” in the PDF Service Guide<sup>1</sup>.

## **Step 28. Position the Cables and Wires to Prevent Pinching**

On the top side of the PNA, carefully position the grey flex cables so they can't be pinched between the covers and the rails.

On the bottom side of the PNA, carefully fold or push down the ribbon cables and wires so they can't be pinched between the hardware and the outer cover. Ribbon cables and wires must never be positioned on top of hardware.

## Step 29. Reinstall the Inner Cover

For instructions, click the Chapter 7 bookmark “Removing the Covers” in the PDF Service Guide<sup>1</sup>.

## Step 30. Reinstall the Outer Cover

For instructions, click the Chapter 7 bookmark “Removing the Covers” in the PDF Service Guide<sup>1</sup>.

## Step 31. Remove Option 219 License

### Procedure Requirements

- The analyzer must be powered up and operating to perform this procedure.
- The Network Analyzer program must be running.
- A keyboard and mouse must be connected to the network analyzer.

### Option 219 License Removal Procedure

1. To start the option enable utility, press UTILITY **System**, then **Service**, then **Option Enable**. An option enable dialog box will appear.
2. Click the arrow in the **Select Desired Option** box. A list of available options will appear.
3. In the **Select Desired Option** list, click **219**.
4. Click **Remove**.
5. Click **OK** to confirm that you want to remove the license for the selected option.
6. Click **Yes** in answer to the displayed question in the **Restart Analyzer?** box.

## Step 32. Enable Options P04 (400) and 419

### Procedure Requirements

- The analyzer must be powered up and operating to perform this procedure.
- The Network Analyzer program must be running.
- A keyboard and mouse must be connected to the network analyzer.

### Option Enable Procedure

1. To start the option enable utility, press UTILITY **System**, then **Service**, then **Option Enable**. An option enable dialog box will appear.
2. Click the arrow in the **Select Desired Option** box. A list of available options will appear.
3. In the **Select Desired Option** list, click **P04 - 4-Ports**.
4. Using the keyboard, enter the license key in the box provided. The license key is printed on the license message you received from Keysight. Enter this key *exactly* as it is printed on the message.
5. Click **Enable**.

6. Click **Yes** in answer to the displayed question in the **Restart Analyzer?** box.
7. Repeat steps 3-6 to enable Option 419, clicking **419 - Src/Rcvr Atten & Bias Ts 4-Port** in step 3.
8. When the installation is complete, click **Exit**.

### Option Verification Procedure

Once the analyzer has restarted and the Network Analyzer program is again running:

1. On the analyzer's **Help** menu, click **About Network Analyzer**.
2. Verify that "P04" and "419" are listed, but "219" is not listed after "Options:" in the display. Click **OK**.

---

**NOTE** If the options have not been enabled or if the option 219 license has not been removed, perform the prior steps again. If the options are still not correct, contact Keysight Technologies. Refer to [Getting Assistance from Keysight](#).

---

## Step 33. Perform Post-Upgrade Adjustments and Calibration

### Adjustments

The following adjustments must be made due to the hardware changes of the analyzer.

- default EE
- source adjustment
- receiver adjustment
- receiver characterization

These adjustments are described in the PNA Service Guide and in the PNA on-line HELP. A list of equipment required to perform these adjustments is also found in the service guide.

After the specified adjustments have been performed, the analyzer should operate and phase lock over its entire frequency range.

### Operator's Check

Perform the Operator's Check to check the basic functionality of the analyzer. For instructions, click the Chapter 3 bookmark "Tests and Adjustments" in the PDF Service Guide<sup>1</sup>.

If you experience difficulty with the basic functioning of the analyzer, contact Keysight. Refer to ["Contacting Keysight" on page 3](#).

### Calibration

Although the analyzer functions, its performance relative to its specifications has not been verified. It is recommended that a full instrument calibration be performed using the analyzer's internal performance test software. To view information on the performance test software, click the Chapter 3 bookmark "Tests and Adjustments" in the PDF Service Guide<sup>1</sup>.

---

1. See ["Downloading the Online PNA Service Guide" on page 5](#).

### **Step 34. Prepare the PNA for the User**

1. If necessary, reinstall front jumper cables.
2. Install the cable guards, pushing them over the front jumper cables until the cushioning material touches the front panel of the PNA.
3. Install the dust caps on the test ports.
4. Clean the analyzer, as needed, using a damp cloth.



This information is subject to change without notice.

© Keysight Technologies 2011 – 2015

March 2015



N5222-90124  
[www.keysight.com](http://www.keysight.com)